



RRONYX1640

Created for the Pro's, the RRONYX1640 mixer case is made for the journey and built to hold strong in high stress situations. Designed to fit the Mackie ONYX 1640 16 ch/4 buss mixer, the RRONYX1640 features a heavy-duty removable, latchable cover with our No Pressure Design to protect your mixer controls and a unique low profile base design that allows you to access your mixer's rear connection panel without removing the mixer from the case. Tougher than the pavement! That's the idea..

Rugged Road Ready Features

- * Double Anchor Industrial Rivets
- * Recessed, Industrial Grade Latches
- * Industrial Grade Rubber Feet
- * Spring Loaded Handle
- * Premium 3/8" Vinyl Laminated Plywood
- * Tongue and Groove Locking Fit
- * Low Profile Base
- * Road Ready Limited Lifetime Warranty

Shipping Dimensions (inch): 27.8 x 19.4 x 7.9

Shipping Weight (lbs): 20.9 lbs

Product Dimensions (inch): 27.4" x 19" x 7.1"

Product Weight (lbs): 17.6 lbs

Shipping Dimensions (cm): 70.7 x 49.2 x 20

Shipping Weight (kg): 9.5 kg

Product Dimensions (cm): 69.7 x 48.2 x 18

Product Weight (kg): 8 kg

5/2005

CASE FOR MACKIE ONYX 1640 MIXER

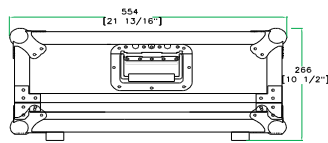

FRONT VIEW

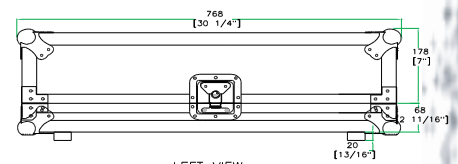

LEFT VIEW

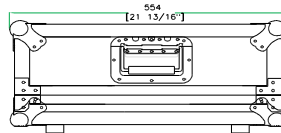

BACK VIEW

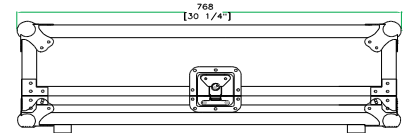

RIGHT VIEW

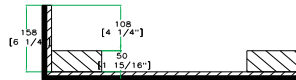

C-C VIEW

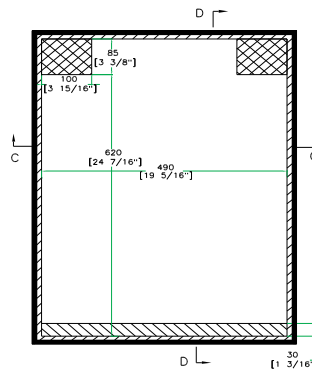

TOP VIEW OF COVER

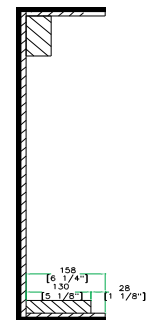

D-D VIEW

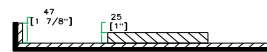

A-A VIEW

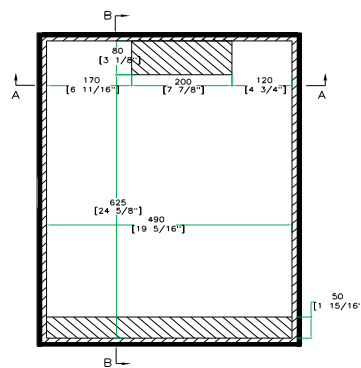

TOP VIEW OF BASE

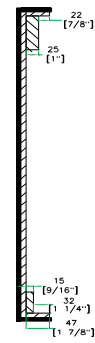

B-B VIEW

www.roadreadycases.com

Road Ready Cases 18120 S. Broadway St. Unit B Gardena, Ca. 90248- 3536
 ph: 310 767 1772 fax: 310 767 1798